

# ***Airports and Malls Proposals***

**Submitted To:**

**Quotation #:** T2020B2907

**Date:** 1<sup>st</sup> August  
2020

**Validity** 30 days

**Description:**

A solution bundle for Space Purifying System to stop the chain of infection.

Our sanitation spraying system was designed to promote hygiene by disinfecting spaces people and the air via integrated spray system that targets defined areas and is capable of spraying our purify Solutions to provide maximum protection against bacteria and Viruses like Covid-19 by vigorously sanitizing all defined areas. Our system sanitizes entire area including aspects that are not directly exposed to the nozzles - thereby decreasing disease transmission without interfering with day to day activity.

# Airports and Malls Proposals

**General Conditions**

Purefic hereby offers to furnish the following described machinery and equipment, and/or services under the terms and prices as stated below, and in accordance with conditions set forth on the last page of this proposal.

This proposal will remain in effect for 30 days unless changed in interim by written notice from Purefic.

**Overall solution**

Purefic solution bundle use electrolyzed water (EW) as sanitization solution for purifying close spaces. We provide a complete solution from producing the solution in small or industrial capacities and varied product line for application from small to large spaces. We offer customizable sanitization programs that are tailor-made for any need.

HOCL is a natural substance our body produces as a first line of defence against pathogens. It is extremely safe, bio- degradable and non-corrosive. It is nonflammable and chemical free. This material was proven to be effective not just against the Corona virus but also against harmful pathogens like MRSA, positive and negative gram bacteria in 99.999999% efficacy (log8 reduction).

**EW Production Unit:**

A Purefic solution has highly effective protective properties against an array of pathogens. The solution undergoes electrolysis in special electro-chemical cells in which the pH of the water is manipulated to be in a well-defined range. The active material is Hypochlorous acid (HOCl) in a concentration range of 50-200 ppm and a pH range between 4.5 and 6.5.

The system has the capability to choose the pH and active material concentration.

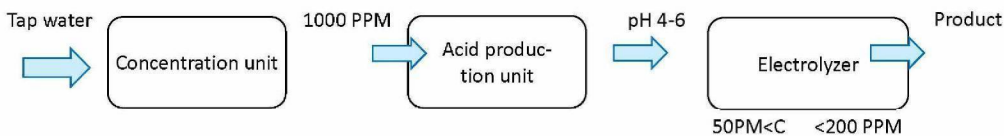

	Qty.	Unit Price (USD)
10 litter/hour (200 ppm) / 40 litter/hour (50 ppm)	1	TBD
150 litter/hour (200 ppm) / 600 litter/hour (50 ppm)	1	TBD
250 litter/hour (200 ppm) / 1000 litter/hour (50 ppm)	1	TBD
Cost Per Litter	1	TBD
Capsule Cost	1	TBD

# *Airports and Malls Proposals*

## What makes us different:

1. When the material is produced on site, there is no caustic by product.
2. The production unit is fully automated and requires minimum maintenance.
3. Our team comprising engineers, electrochemist and microbiologists covering all aspects.
4. We have technologies to keep the material stable after it is produced.
5. We can tailor the product in accordance to the desired application considering all the parameters.
6. We produce the material with its optimal composition.
7. Salinity is very low and so the corrosion potential of the solution

## Sanitary Tunnels:

Turn any commercial space into a safe space with our fully customizable full-body disinfection tunnels line.

Our innovative system easily sanitizes people and their items. Once inside the tunnel, the spray nozzles will automatically open for seconds and sanitize every facet of those passing through, including areas not directly exposed to the nozzle.

Our line of tunnels can fit any use and traffic capacity.

Tunnels are equipped with traffic light and sensors that recognizes when people are passing through and start the spraying system automatically, no need for operator.

On average tunnel is using 6ml of EW solution per person.

### Tubular

- Fully transparent design with external operation unit.
- Designed for indoor use.
- Can be dismantled for storage / transportation.
- Array of up to 6 mist nozzles.
- Sanitization process of 7-10 second per person, one at a time.
- Output of 100-200 persons per hour.

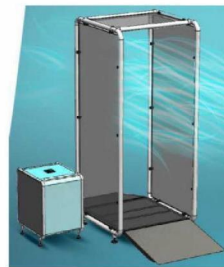

## *Airports and Malls Proposals*

### Basic

- Small layout with build in operation unit
- Designed for indoor use.
- Array of up to 6 mist nozzles.
- Sanitization process of 5-7 second per person, one at a time.
- Output of 200-400 persons per hour.

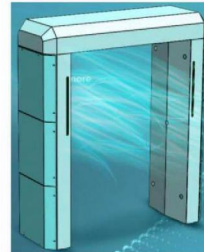

### Standard

- Medium layout with build in operation unit.
- Designed for outdoor use.
- Array of up to 10 mist nozzles.
- Sanitization process of 3 second per person, one at a time.
- Output of 700-1200 persons per hour.
- Optionally can operate with automatic Pure-fic production unit.



### Premium

- Extra-long layout with build in operation units.
- Designed for outdoor use.
- Array of up to 20 mist nozzles.
- Sanitization process – continuous.
- Output of 3600 persons per hour.
- Optionally can operate with automatic Pure-fic production unit.

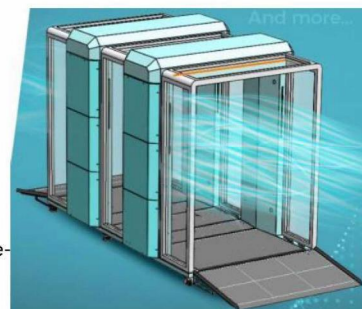

## Airports and Malls Proposals

Item	Unit Price (USD)			
	Tubular	Basic	Standard	Premium
1-2	TBD	TBD	TBD	TBD
3-5	TBD	TBD	TBD	TBD
6-20	TBD	TBD	TBD	TBD
21-100	TBD	TBD	TBD	TBD

### Gate Portable Tunnel

- Small portable tunnel with build in operation unit
- Designed to be transported from gate to gate manually by hands.
- Mounted on wheels for easy maneuvering.
- Array of up to 6 mist nozzles.
- Sanitization process of 5 second per person, one at a time.
- Output of 200-400 persons per hour.

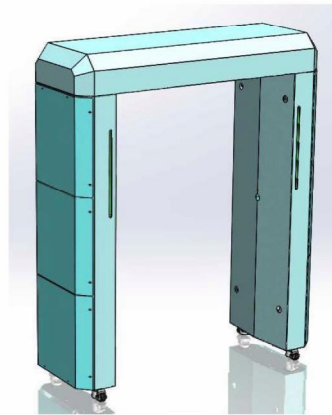

### Carry-on Luggage Sanitizer

- Small tunnel to be installed in-line of carry-on luggage security check to sanitize trays with personal belongs.
- Array of up to 6 mist nozzles.
- Sanitization in real time.
- Size of tunnel can be customize
- Can be installed on any existing system.

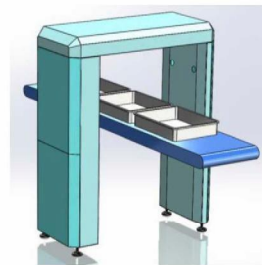

### Baggage claim/check in Sanitizer

## Airports and Malls Proposals

- Tunnel to be installed in-line after check-in baggage process before loading on the plane.
- Tunnel to be installed in-line before going to baggage claim area after unloading loading from plane.
- Include raised partially hollow conveyor to allow access from below for full luggage sanitation.
- Designed to maximize the coverage of sanitizing solution on all surface of the baggage.
- Array of up to 6 mist nozzles.
- Sanitization in real time.
- Size of tunnel can be customizing.
- Can be installed on any existing conveyor system.

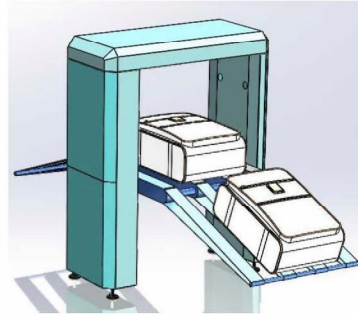

Item	Unit Price (USD)		
	Gate Portable Tunnel	Carry-on Luggage Sanitizer	Baggage Sanitizer
1-2	TBD	TBD	TBD
3-5	TBD	TBD	TBD
6-20	TBD	TBD	TBD
21-100	TBD	TBD	TBD

\*prices do not include customization and may be vary according to sizes.

### Indoor sanitization towers:

Disinfect and tackle areas with plug & play sanitization towers.

## ***Airports and Malls Proposals***

Easy to use touch screen control panel to adjust time and frequency of operation and Preset Sanitation programs

Remote control via Wi-Fi connection allow schedule operation and monitoring of solution low level

Motion sensor

Use Purefic patented filled Capsules with Purefic solution.

Variable automated spray settings.

On average it takes 5-10 min to cover an area.

Slick design to integrate any space.

This solutions DO NOT require EW production unit.

### Purific-P05

- Designed for Small area /targeted location
- Wall mounted
- Capsule size , capacity: 0.5 to 1L
- Voltage: 110V/5 V220.0/60Hz
- Battery option
- Power: 30W
- Purify usage: up to 50-100ml/h
- Color: White
- Motion Sensor
- Different operational programs are settings
- Dimensions: 150X250X350mm



### Purific-P10

- Designed for Small spaces 25 to 50 SQM
- Capsule size , capacity: 1 to 5L
- Voltage: 110V V22050/60Hz
- Power: 48W
- Purify usage: up to 700 ml/h
- Color: White
- LED display



## Airports and Malls Proposals

- Motion Sensor
- Different operational programs are settings
- Dimensions: 350X3350X2000mm

### Purific-P20

- Designed for large spaces
- Capsule size , capacity: 20L
- Voltage: 110V/5 V220.0/60Hz
- Power:110W
- Purify usage: up to 1500 ml/h
- Color: White
- LED display
- Motion Sensor
- Different operational program settings
- Dimensions: 450X450X2300mm



Item	Unit Price (USD)				
	P5000	P13000	05P	P10	P20
1-100	TBD	TBD	TBD	TBD	TBD
101-500	TBD	TBD	TBD	TBD	TBD
501-1000	TBD	TBD	TBD	TBD	TBD
1001-2000	TBD	TBD	TBD	TBD	TBD

### Payment Terms

- 50% Down payment at the time this Agreement is executed and a purchase order is placed.
- 50% On shipping notification, prior to shipping.

### Delivery Terms

Delivery time variants depending on units. Ready for shipment Estimated 6-10 weeks (EX-Works Purific) after receipt of purchase order and clarification of all technical and commercial details and receipt of down payment.

# ***Airports and Malls Proposals***

Stated delivery for this proposal is based on current factory loading and is subject to change at time of order placement. Delivery and installation cost are not included.

## **Machine Devices and Parts**

The machine is set to work in a humid environment. All the product contact parts are stainless steel. The machine is constructed of stainless steel, anodized aluminum and plastic, all of which conform to CE, UL, 3A, FDA Grade A standards. All required approvals from local safety and standards agencies are the responsibility of the Buyer. Purefic agrees to meet recommendations made by these agencies.

## **Safety**

Purefic Equipment is designed to comply with Safety Standards to the best of our abilities and interpretation. Full compliance with local Safety Standards involves the use of the equipment at the customer's location and therefore is not fully controllable by the manufacturer. We cannot, therefore, certify that our equipment conforms in all respects with your local Safety Standards. Upon Buyer's inspection and testing at Seller's location, any specific requirements of Buyer to address regulations requiring additional work by Seller will be quoted by Seller. Seller does not represent or warrant that equipment sold by it complies with any like state / provincial or local law or regulation, and the cost of modifications and responsibility for compliance are the Buyer's responsibility.

## **Documentation**

Operation and maintenance manuals are included with the machine in both hard copy and digital formats.

## **Terms and Conditions Of Sale**

These Terms and Conditions of Sale shall cover the product sold by Purefic. to the original buyer ("Buyer") as described in the product's purchase order, manuals, and other attached documentation ("Product"). Buyer hereby acknowledges and agrees to the following Terms and Conditions of Sale:

## **Pricing**

All prices, terms, discounts, and specifications are subject to change with 60-day notice. Unless otherwise agreed upon in writing signed by Purefic and the Buyer, orders will be billed at the prices in effect at the time of accepted order. Prices are exclusive of federal, State/Province, or local taxes of any nature. The Buyer shall pay all taxes applicable to Products ordered. If Buyer is exempt from any kind of tax, Buyer shall provide Purefic. with a tax exemption certificate acceptable to taxing authorities. In the absence of a tax exemption certificate, taxes will be charged and payable until a valid tax exemption certificate is on file.

## **Payment Terms**

Unless otherwise expressly agreed to in the purchase order, payment terms to Buyer are cash before delivery. Past due or otherwise delinquent account balances, or any part thereof, are subject to a service charge equaling the lesser of 1.50% per month until paid or the

## ***Airports and Malls Proposals***

legal maximum allowable in the Buyer's State/Province. Past due or otherwise delinquent account balances may, at the sole option of Purefic be placed for collection. The Buyer hereby agrees to pay all expenses incurred including but not limited to collection fees, court costs, and reasonable attorney fees. In the event any of Buyer's payments are not promptly made when due, Buyer shall be in default of these Terms and Conditions of Sale and all unpaid amounts shall immediately become due and payable. In the event Buyer's account is past due or otherwise delinquent, the Buyer agrees that Purefic may offset the account balance, or any portion thereof, against any funds of the Buyer held by Purefic.

### **Warranties and Limitation On Liability**

Purefic warrants all Products to be free from defects in material and workmanship for a term established by the specific warranty included with a Purefic Product (the "Product Warranty"). The obligations of Purefic under the Product Warranty shall be limited to the repair or exchange or giving credit for, at the option of Purefic, any Products which may thus prove defective in accordance with evidence satisfactory to Purefic. Any repair or replacement of Products by Purefic shall not extend the original Product Warranty period. In the event a warranty is not included with the Purefic Product, the warranty set forth in these Terms and Conditions of Sale shall be the Product Warranty and the term of such Product Warranty shall be twelve months from the date of shipment from Purefic to Buyer. The Product Warranty shall not apply to any Products that have been subject to accident, negligence, unauthorized alteration or repair, abuse of misuse, or unusual stress. Purefic expressly disclaims all other warranties, including but not limited to any warranties of merchantability or fitness for a particular purpose. Purefic Shall in no event be liable for any special, indirect, incidental, consequential or punitive damages or for loss, damage, or expense, including loss of use, profits, revenue, or goodwill, directly or indirectly arising from buyer's use or inability to use the products, or for loss or destruction of other property or from any other cause, even if Purefic Has been advised of the possibility of such damage. The liability of Purefic shall in no event exceed an amount equivalent to the purchase price paid by the buyer.

### **Buyer's Purchase Order; Acceptance Of Orders; Conflict Of Terms**

All purchase orders are subject to acceptance by Purefic in its sole discretion. No sales are final until accepted in writing by Purefic. In the event the Buyer shall submit a purchase order, the written terms of which are in conflict with these Terms and Conditions of Sale, these Terms and Conditions of Sale stated herein shall prevail. Any attempt to modify these Terms and Conditions of Sale or subject Purefic to additional terms and conditions shall be null and void, unless Purefic and the Buyer shall have first entered into a signed agreement making such modifications or imposing such additional terms and conditions. A purchase order placed by Buyer and accepted by Purefic shall not be cancelled thereafter by Buyer without Purefic's written consent, and such consent may require indemnification for any loss suffered by Purefic. Shipments will be made upon Purefic's acceptance of Buyer's order. Acceptance includes approval of credit in accordance with Purefic's customary terms.

### **Delivery**

## ***Airports and Malls Proposals***

Products are shipped pursuant to the Product's purchase order. Purefic shall not be responsible for shipping delays caused, directly or indirectly, by circumstances which are beyond its control. Risk of loss due to damage, shortage or non-delivery due to carrier fault lies with the Buyer. The Buyer should make all claims for damage or shortages to carrier immediately upon receipt of material. Any claims stemming from discrepancies between the invoiced descriptions or quantities and the actual Product received by the Buyer alleged to be due to error by Purefic must be made in writing within thirty 30 days of the invoice date. Any such claim not presented within the time specified will be waived and actual delivery of invoice descriptions or quantities will be deemed accurate. Any default by the Buyer of these Terms and Conditions, including but not limited to, failure to make timely payment on any order of Products or failure to make timely payment for any amounts due by the Buyer to Purefic, shall also constitute a basis for cancellation or postponement of delivery by Purefic of any order placed by Buyer even if such order has already been approved by Purefic.

### **Title Assignment**

Although title and risk of loss passes to Buyer at point of shipment, the Buyer hereby grants Purefic a lien to secure payment, regardless of physical location of the goods. Said lien survives until payment in full has been received by Purefic

### **Product Installation And Operation**

Installation of Products shall only be performed by Purefic or its agents. Buyer assumes all responsibility for the proper operation and maintenance of the Products purchased from Purefic shall not be responsible or liable in any way, in whole or in part, for any damages, including, but not limited to, any special, incidental, consequential or punitive damages arising from any claim or theory whatsoever, except as specifically set forth in the Limited Warranty clause in paragraph 3 hereof.

### **Authority Of Buyer's Personnel**

Purefic is entitled to rely upon the apparent authority of all of Buyers' employees and agents who place orders for or on behalf of Buyer.

### **Severability; Modification And Waiver; Assignment**

In the event that any provision of these Terms and Conditions is found to be unenforceable in any legal proceeding, the remaining provisions shall remain in full force and effect. No modification or waiver of the terms contained herein shall be effective unless authorized in writing signed by a duly authorized officer of Purefic and Buyer. No course of dealing between the parties or any failure or delay on the part of Purefic in exercising any rights or remedies, and no single or partial exercise of any rights or remedies hereunder, shall operate as a waiver or preclude the exercise of any other rights or remedies hereunder. Buyer's rights hereunder cannot be assigned nor can the performance of its obligations be delegated without the prior written consent of Purefic

## ***Airports and Malls Proposals***

### **Notices; Change Of Buyer's Name Or Address; Reorganization**

All notices permitted or required pursuant to these Terms and Conditions shall be sent by registered or certified mail, addressed to the parties at their principal offices until notice of a change of address or contact person is given to the party. Such written notice shall be effective as of the third business day from the date of posting. Buyer hereby agrees to immediately notify Purefic in writing of any changes of name or address, or of any corporate reorganization or change of ownership regardless of whether it results in a change of name or location of the Buyer.

### **Governing Law; Consent To Jurisdiction**

These Terms and Conditions of Sale shall be governed by and construed in accordance with the laws of the United Kingdom. Buyer hereby irrevocably consents to exclusive jurisdiction in courts of the United Kingdom and of any federal courts located in the United Kingdom. Notwithstanding the above, in the event of a dispute regarding non-payment, Purefic shall have the right in its sole discretion to pursue legal action against Buyer in any court of competent jurisdiction, including, without limitation, any federal or state court located in a different state. In the event Purefic institutes any legal proceeding against Buyer including a proceeding to collect any amount due by Buyer hereunder, Buyer shall be liable to Purefic for all legal fees and costs as well as collection costs and expenses (including reasonable attorney's fees for such collection) incurred in connection therewith. The parties expressly waive trial by jury and waive any right to object on the basis of inconvenient forum or venue in all the above jurisdictions.

The undersigned hereby certifies that he/she has read and agrees to the above Terms and Conditions of Sale and certifies that the information submitted, and any other documents submitted, is true and correct, and that the undersigned is duly authorized to sign this Agreement on behalf of the Buyer.

Accepted By:	Confirmed By:
Mr.	5.1.2e
Title:	Title: Authorized Agent for Purefic
Signature:	Signature:
Date:	Date: August 1, 2020
Company:	Company Contact: U.S. Defense Team Email: <a href="mailto:Info@usdefensetea.com">Info@usdefensetea.com</a> Phone Number: 5.1.2e 5.1.2e for Video Presentations.